

NOTE:
Please read all
instructions carefully
before using this product

Table of Contents

Safety Notice

Important Assembly
Information

Care and Maintenance

Parts List

Warranty

Ordering Parts

Model
MD-5139

Retain This
Manual for
Reference

170630

**OWNER'S
MANUAL**

MARCY®

MARCY PRO SMITH MACHINE MD-5139

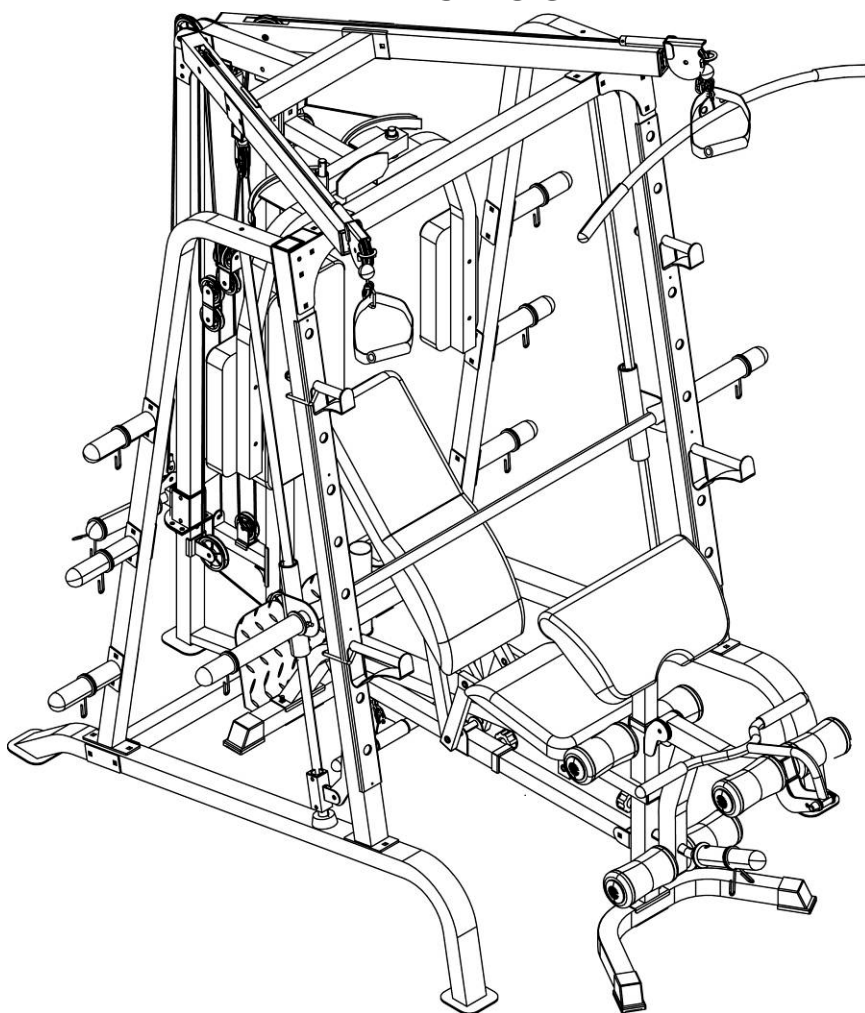

IMPORTANT: Please read this manual before commencing
assembly of this product.

IMPEX® INC.

2801 S. Towne Ave, Pomona, CA 91766

Tel: 800-999-8899

www.marcypro.com

support@impex-fitness.com

TABLE OF CONTENTS

BEFORE YOU BEGIN.....	1
IMPORTANT SAFETY NOTICES.....	2
EXERCISE GUIDELINES.....	3
WARNING LABEL PLACEMENT.....	5
FREE AND TRAINING AREA.....	6
IMPORTANT ASSEMBLY INFORMATION.....	7
CABLE ASSEMBLY INSTRUCTION.....	9
WEIGHT CAPACITY AND DIMENSION.....	18
CARE AND MAINTENANCE.....	19
OPERATING NOTES.....	19
WEIGHT RESISTANCE CHART.....	20
SMITH MACHINE PARTS LIST.....	21
SMITH MACHINE EXPLODED DIAGRAM.....	24
BENCH PARTS LIST.....	25
BENCH EXPLODED DIAGRAM.....	26
WARRANTY.....	27
ORDERING PARTS.....	27

BEFORE YOU BEGIN

Thank you for selecting MARCY PRO SMITH MACHINE MD-5139 by IMPEX[®] INC. For your safety and benefit, read this manual carefully before using the equipment. As a manufacturer, we are committed to providing you with complete customer satisfaction. If you have any questions, or find there are missing or damaged parts, we guarantee you complete satisfaction through direct assistance from our factory. To avoid unnecessary delays, *please call our TOLL-FREE customer service number.* Our Customer Service Agents will provide immediate assistance.

Toll-Free Customer Service Number

1-800-999-8899

Mon. – Fri. 9 a.m. – 5 p.m. PST

www.marcypro.com

support@impex-fitness.com

IMPORTANT SAFETY NOTICE

This exercise equipment is built for optimum safety. However, certain precautions apply whenever you operate a piece of exercise equipment. Be sure to read the entire manual before you assemble or operate your equipment. In particular, note the following safety precautions:

1. **Keep children and pets away from the equipment at all times. DO NOT leave children unattended in the same room with the equipment.**
2. Only one person at a time should use the equipment.
3. If the user experiences dizziness, nausea, chest pain, or any other abnormal symptoms, STOP the workout at once. CONSULT A PHYSICIAN IMMEDIATELY.
4. Position the equipment on a clear, leveled surface. DO NOT use the equipment near water or outdoors.
5. Keep hands away from all moving parts.
6. Always wear appropriate workout clothing when exercising. DO NOT wear robes or other clothing that could become caught in the equipment. Running or aerobic shoes are also required when using the equipment.
7. Use the equipment only for its intended use as described in this manual. DO NOT use attachments not recommended by the manufacturer.
8. Do not place any sharp object around the equipment.
9. Disabled persons should not use the equipment.
10. Before using the equipment to exercise, always do stretching exercises to properly warm up.
11. Never operate the equipment if the equipment is not functioning properly.
12. A spotter is recommended during exercise.
13. **This equipment is designed and intended for home and consumer use only, not for commercial use.**

WARNING: BEFORE BEGINNING ANY EXERCISE PROGRAM, CONSULT YOUR PHYSICIAN. THIS IS ESPECIALLY IMPORTANT FOR INDIVIDUALS OVER THE AGE OF 35 OR PERSONS WITH PRE-EXISTING HEALTH PROBLEMS. READ ALL INSTRUCTIONS BEFORE USING ANY FITNESS EQUIPMENT. IMPEX INC. ASSUMES NO RESPONSIBILITY FOR PERSONAL INJURY OR PROPERTY DAMAGE SUSTAINED BY OR THROUGH THE USE OF THIS PRODUCT.

SAVE THESE INSTRUCTIONS.

EXECISE GUIDELINES

Building Muscle and Gaining Weight

Unlike aerobic exercise, which emphasizes endurance training, anaerobic exercise focuses on strength training. A gradual weight gain can occur while building the size and strength of muscles. While developing muscle mass, your body adapts to the stress placed upon it. You can modify your diet to include foods such as meat, fish and vegetables. These foods help muscles recover and replenish important nutrients after a strenuous workout.

Muscle Strength and Endurance

To achieve the greatest benefit from exercise, it is important to develop an exercise program that allows you to work all of the major muscle groups equally.

To increase muscle strength, follow this principle:

Increasing resistance and maintaining the number of repetitions of an exercise results in increased muscle strength.

To tone your body, follow this principle: Decreasing resistance plus increasing the number of repetitions of an exercise results in increased body tone.

Once you feel comfortable with an exercise, you can change the resistance, the number of repetitions, or the speed at which you do the exercise. It is not necessary to change all three variables. For example, let's say that you are training at 23 kg (50 lb.) and performing the exercise 10 times in 3 minutes. When this becomes too easy, you may decide to move up to lifting 27 kg (60 lb.) for the same number of repetitions in the same amount of time. Lifting more weights fewer times most often develops muscle strength. To gain both muscle strength and endurance, it is recommended that you perform each exercise 15 to 20 reps per set.

Training Intensity

How hard you begin to train depends on your overall level of fitness. The soreness you experienced can be lessened by decreasing the load you place on your muscles and by performing fewer sets. To avoid injury, you should gradually work into an exercise program and set the load to your individual fitness level. The load should increase as your fitness level increases.

Muscle soreness is common, especially when you first start exercising. If you are painfully sore for a long time, it may be time to change your program. Eventually, your muscle system will become accustomed to the stress and strain placed on it.

Beginning a Strength Building Program

Warming Up

To begin strength training, it is important to stretch and perform light exercise for 5 to 10 minutes. This helps prepare the body for more strenuous exercise by increasing circulation, raising your body temperature and developing more oxygen to your muscles.

Workout

For each workout, to keep in mind that muscle soreness that lasts for a long period is not desirable and may mean that injury has occurred.

Cool Down

At the end of each workout, perform slow stretching exercises for 5 to 10 minutes. Ease into each stretch only going as far as you can. This stage allows your muscles to wind down after training.

To provide a total workout program it is also recommended that 2 to 3 days of aerobic exercise is performed in addition to the strength training.

Drinking Water

For the body to function properly, it must be properly hydrated. If you are exercising, you should increase your fluid intake. The reason for this is that the water you take in will leave your system through the sweating mechanism that cools your body during exercise. The water you lose through exercise must be replaced so that the muscles can recover properly.

Rest Day

Although you may not feel like doing it, taking a rest day at least once a week is important because it gives your body a chance to heal itself. Continuously working your muscles will result in over-training, which will not benefit you in the long run.

WARNING LABEL PLACEMENT

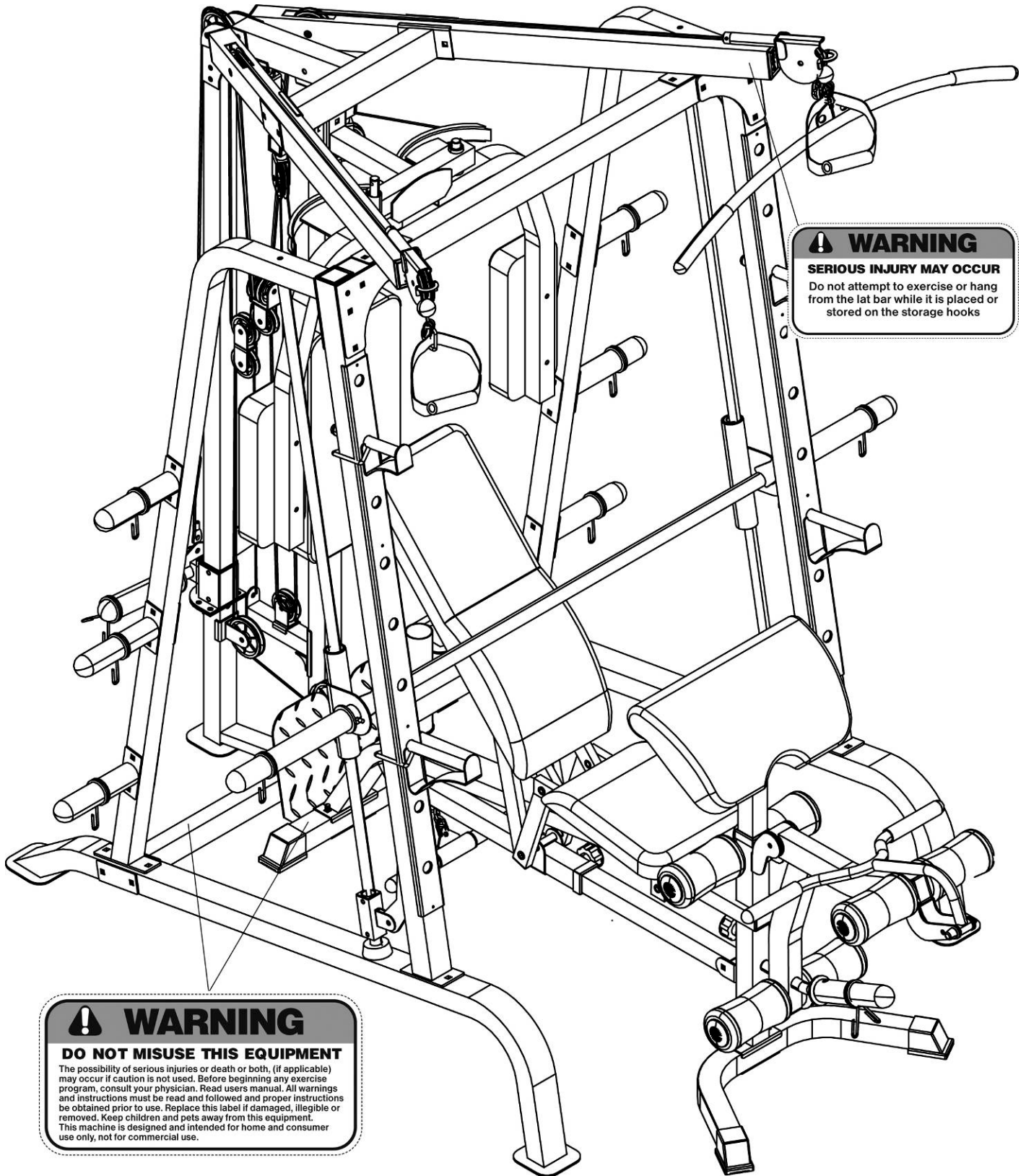

The warning labels shown here have been placed on the Cross Brace, Rear Stabilizer, and Upper Frame. If the labels are missing or illegible, please call customer service at 1-800-888-8899 for replacements. Apply the labels in the location shown.

FREE AND TRAINING AREA

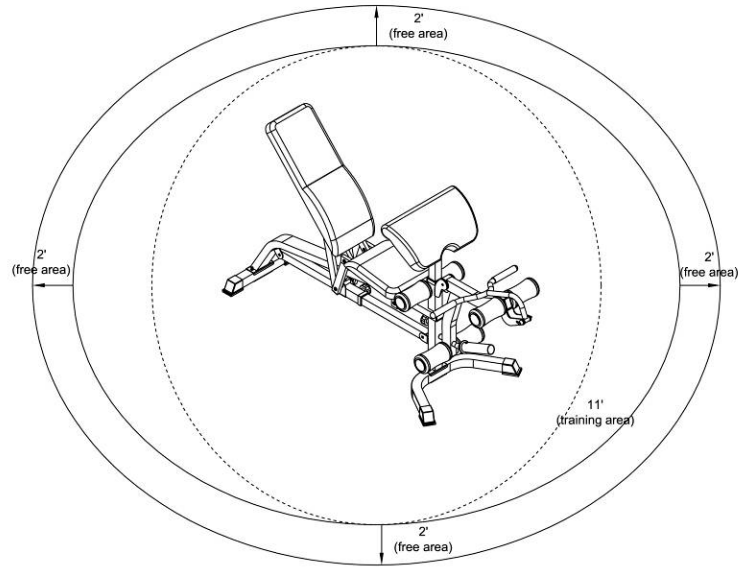
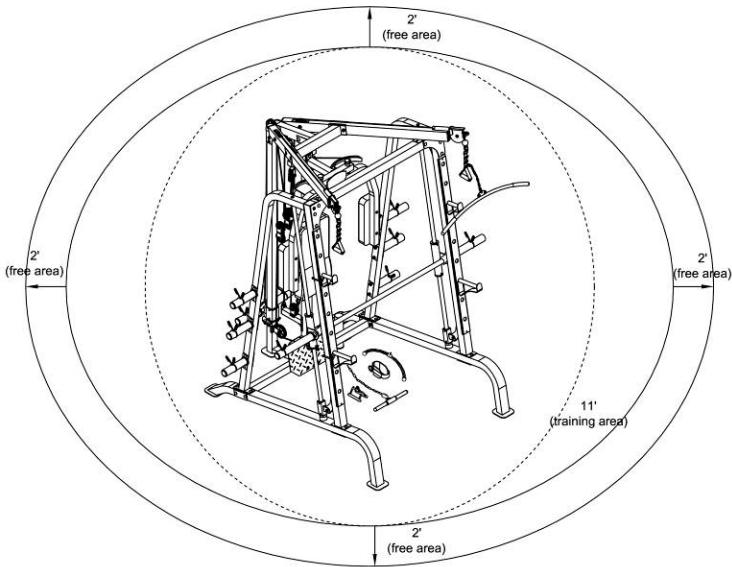
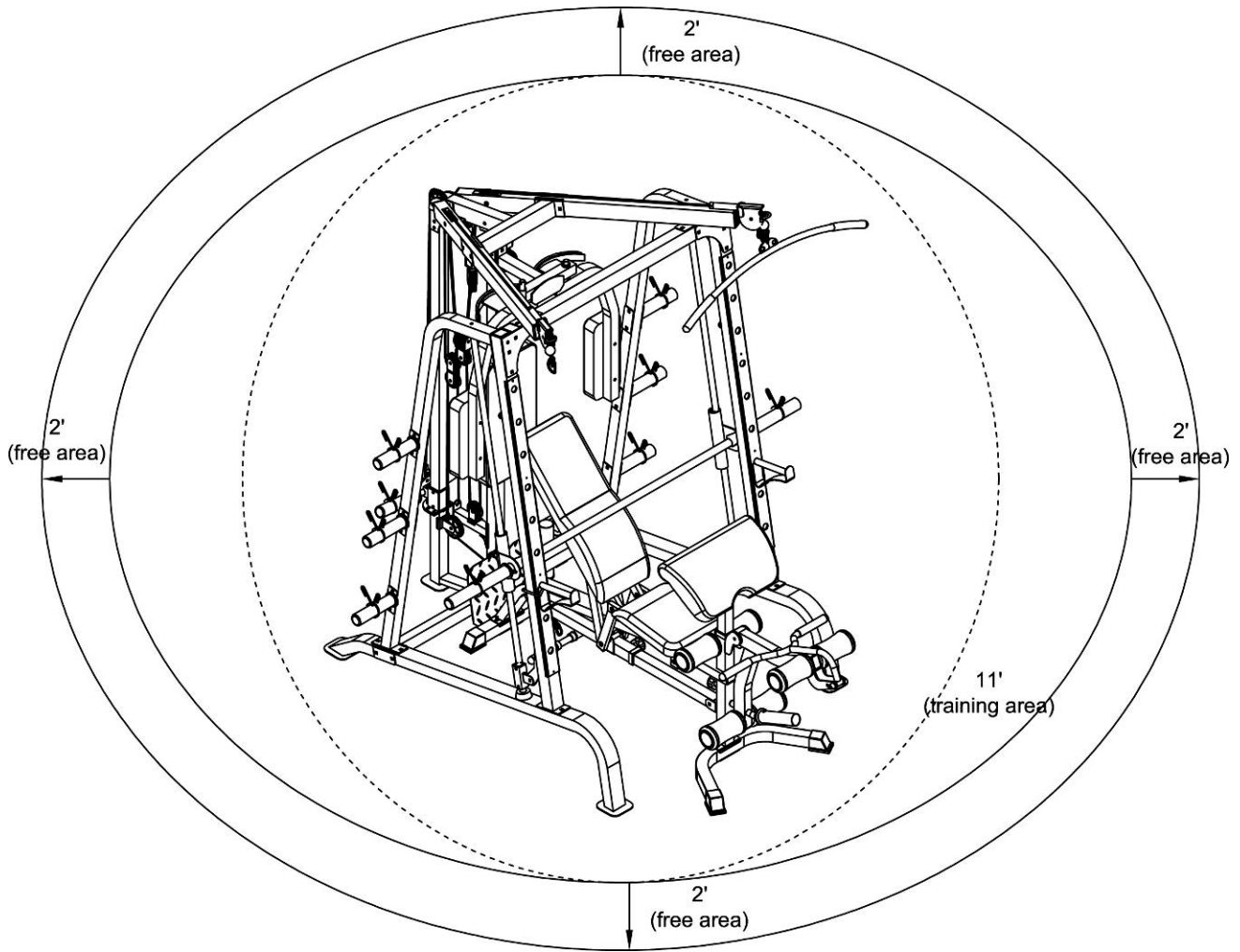

IMPORTANT ASSEMBLY INFORMATION

- ❖ Tools required for assembling the bench: Two adjustable Wrenches and Allen wrenches.
- ❖ NOTE: It is strongly recommended that this equipment be assembled by two or more people to avoid possible injury.
- ❖ Ensure **Carriage Bolts** are inserted through the **SQUARE holes** on components that need to be assembled. Attach washer only to end of the Carriage Bolt.
- ❖ Use **Allen Bolts or Hex Bolts** inserted through the **ROUND hole** on components that need to be assembled.
- ❖ Always wait until all bolts are assembled onto the bench before tightening the bolts. Do not tighten each bolt right after it is installed

Fasten Nuts and Bolts

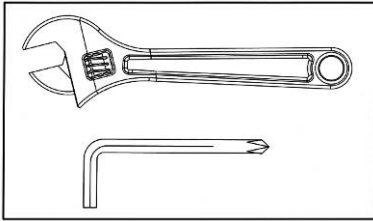

Securely tighten all nuts and bolts after all components have been assembled in current and previous steps.
NOTE: Do not over-tighten any component with pivoting function.
Make sure all pivoting components are able to move freely.

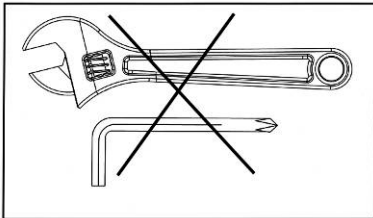

Do not tighten all nuts and bolts in this step.

- ❖ **Inspect and ensure all bolts and Nuts are fastened after the equipment is completely assembled.**

Assemble with correct Hardware Pack

- ❖ Only use the hardware packs marked “For Smith Machine” to assemble Smith Machine.
- ❖ Only use the hardware packs marked “For Bench” to assemble Bench.

Tools

Tools required for assembling this equipment: Allen Wrenches (provided by manufacturer), and Adjustable Wrench, or Socket Wrench, or Ratchet Wrench.

NOTE: It is strongly recommended that this machine be assembled and moved by two or more people to avoid possible injury.

Assemble Sliding Weight Post in assembly Step-6

The triangular bracket on the Sliding Weight Post (Part #14) must be facing up and toward to back.

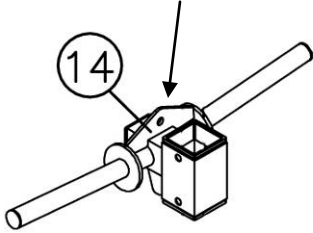

Weight Bar Assembly Note

NOTE: Help of another person is strongly recommended for this step. Place the Lifting Sleeve (#27) in between the two Safety Stop Frames (#26). Align the holes. Insert the Weight Bar (#28) into the Safety Stop Frame from one end and through the Lifting Sleeve (#27) to the other Safety Stop Frame on the opposite side. Secure the Weight Bar to each Safety Stop Frame with two M8 x 3/8" Allen Bolts (#81) on each Safety Stop Frame. Ensure the Bolts are fastened so the Weight Bar won't slide through the Safety Stop Frame.

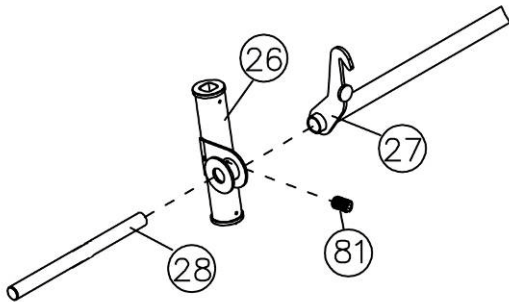

SMITH MACHINE CABLE ASSEMBLY INSTRUCTION

Cable Loop Diagram

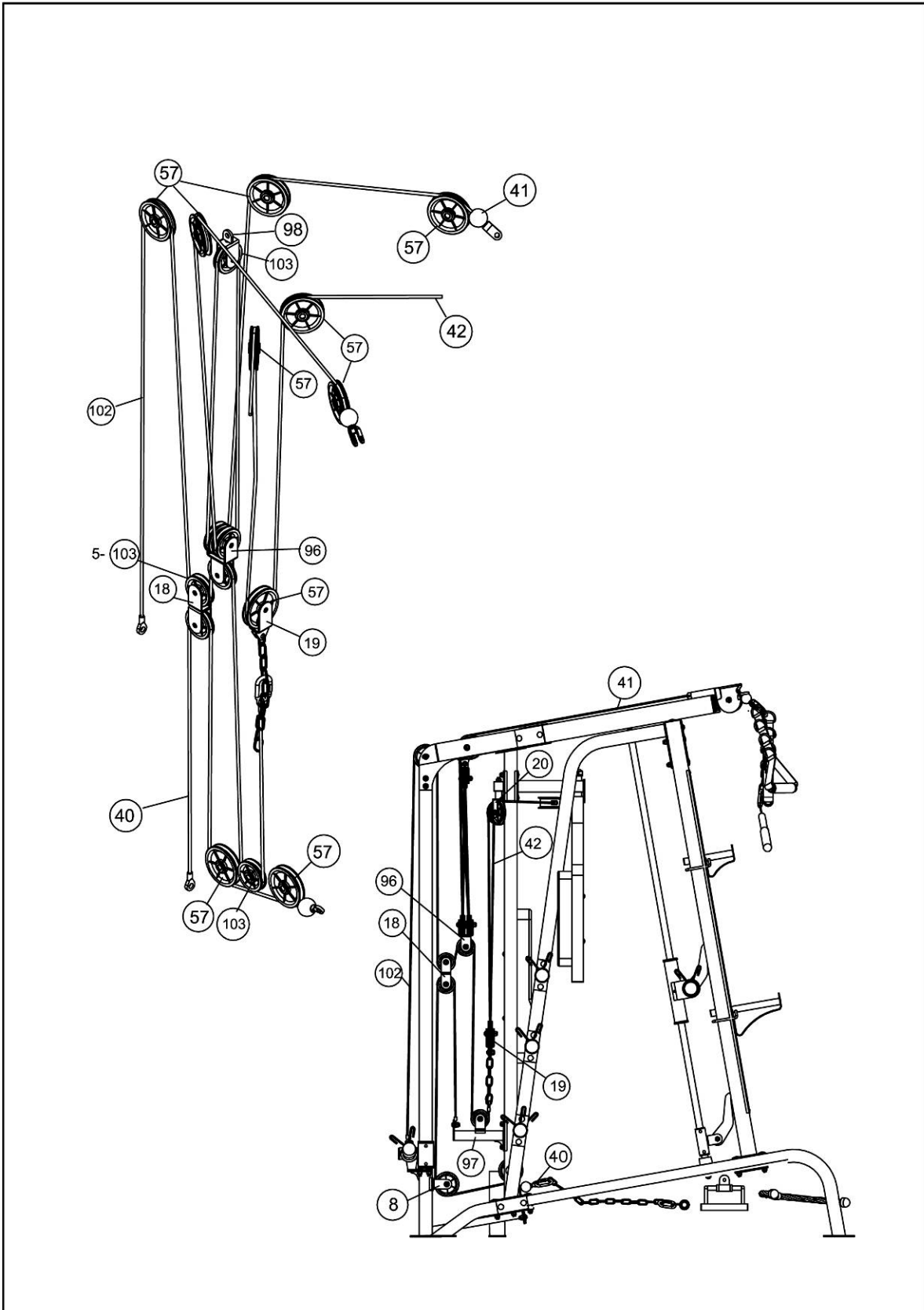

Butterfly Cable assembly instruction Step-10

- A.) Attach one end of 87" Butterfly Cable (#42) to the clip on Right Butterfly (#11). Draw the Cable to the right Swivel Pulley Bracket (#20).
- B.) Attach a Pulley (#57) to the Bracket. Secure it with one M10 x 1 3/4" Allen Bolt (#69), two Ø 3/4" Washers (#66), and one M10 Aircraft Nut (#86).
- C.) Draw the Cable around the Pulley then downward. Attach a Single Floating Pulley Bracket (#19) to the Cable. Repeat Procedure B above to install a Pulley. Let the Bracket hanging for now.
- D.) Draw the Cable around the Pulley then upward to the left Swivel Pulley Bracket. Repeat Procedure B above to install a Pulley to the Bracket.
- E.) Draw the Cable around the Pulley then clip to the Left Butterfly (#10).

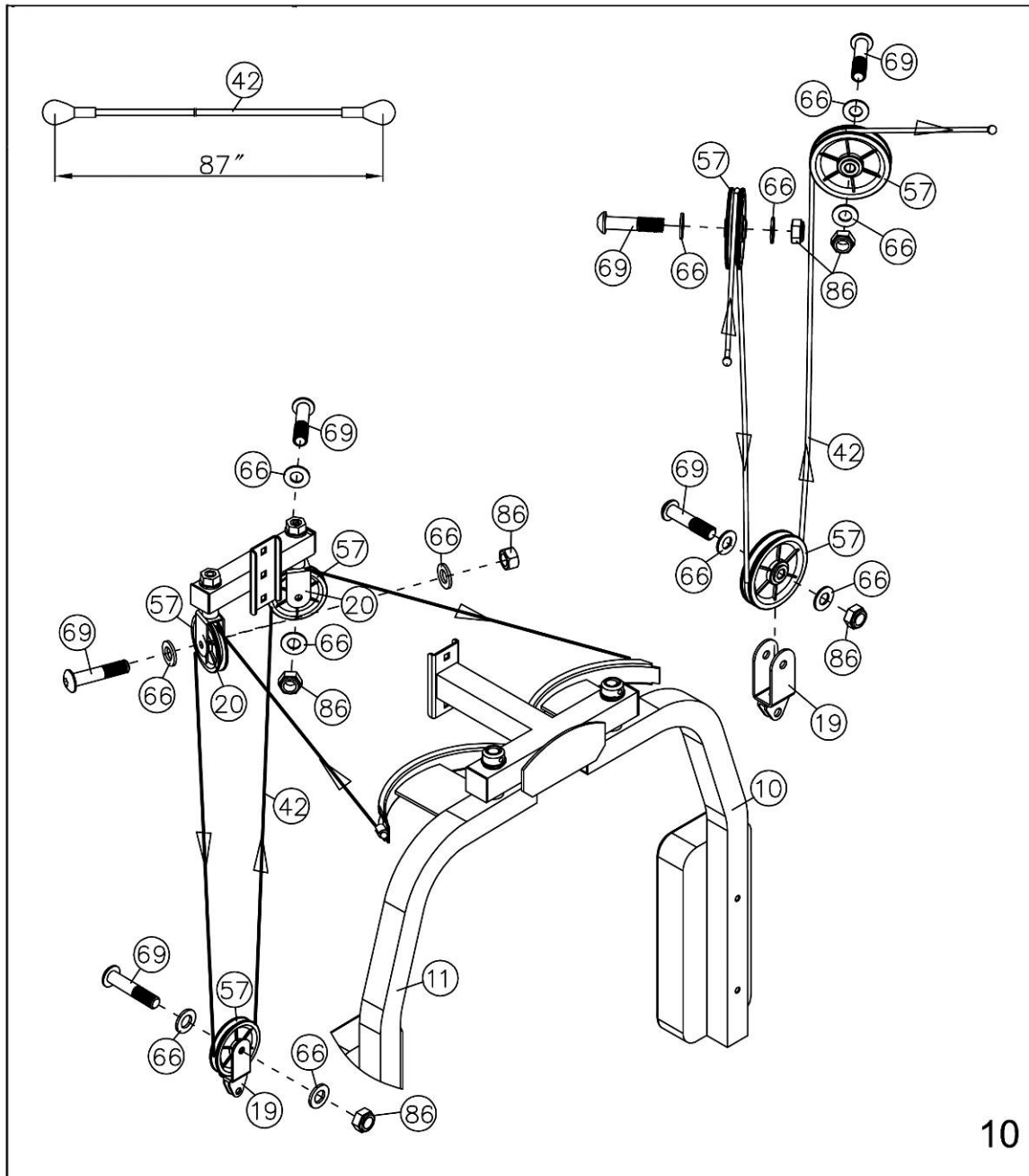

Upper Cable assembly instruction Step-11, Step-11A-B, Step-11-C

- A.) Remove the U-shaped Connector, Big Washer, and Ball Stopper from one end of the 229" Upper Cable (#41).
- B.) Insert this End through the left Cross-over Swivel Pulley Bracket (#99). Attach a Pulley (#57) to the Swivel Bracket and secure it with one M10 x 1 3/4" Allen Bolt (#69), two Ø 3/4" Washers (#66), and one M10 Aircraft Nut (#86). Draw the Cable over the Pulley and pull it toward the back of the machine.
- C.) Draw the Cable along the Left Upper Frame (#94) to the opening on the rear of the Left Upper Frame. Drop the Cable through the opening.
- D.) Attach a Pulley to the opening. Secure it with one M10 x 2 1/2" Allen Bolt (#70), two Pulley Bushings (#62), and one M10 Aircraft Nut (#86). Draw the Cable around the Pulley then downward.
- E.) Attach a Single Small Pulley Bracket (#98) to the bracket underneath the Rear Upper Frame (#9). Secure it with one M10 x 1" Allen Bolt (#68) and one M10 Aircraft Nut (#86).
- F.) Attach two Small Pulleys (#103) to the Triple Floating Pulley Bracket (#96). Secure them with one M10 x 2 3/4" Allen Bolts (#105), two Ø 3/4" Washers (#66), and one M10 Aircraft Nut (#86). Draw the Cable around the front Small Pulley (closer to Butterfly) then upward to the Single Small Pulley Bracket (#98) installed in Procedure E. Attach a Small Pulley (#103) to the Small Pulley Bracket (#98). Secure the Small Pulley with one M10 x 1 3/4" Allen Bolt (#69), two Ø 3/4" Washers (#66), and one M10 Aircraft Nut (#86).
- G.) Draw the Cable around the Small Pulley then downward to the Triple Floating Pulley Bracket. Draw the Cable around the Small Pulley (closer to the Sliding Weight Post) then upward to the opening on the rear of Right Upper Frame (#95). Let the Triple Floating Pulley Bracket hanging for now.
- H.) Attach a Pulley to opening on the rear of Right Upper Frame. Secure it with one M10 x 2 1/2" Allen Bolt (#70), two Pulley Bushings (#62), and one M10 Aircraft Nut (#86). Draw the Cable over the Pulley along the top of the right Cross-over Swivel Pulley Bracket. Attach a Pulley (#57) to the Swivel Bracket and secure it with one M10 x 1 3/4" Allen Bolt (#69), two Ø 3/4" Washers (#66), and one M10 Aircraft Nut (#86).
- I.) Re-install the Ball Stopper, Big Washer, and the U-shaped Connector removed in Procedure A above. Secure this end and the other end of Cable with one M10 x 1 1/8" Allen Bolt (#104) and one M10 Aircraft Nut (#86).
- J.) Connect a Single Handle Strap (#90) to each end of the Cable with a C-clip (#61).
- K.) When using the Lat Bar (#29), remove one of the Single Handle Strap and connect the Lat Bar to the Cable end with a Short Chain (#63) and two C-Clips.

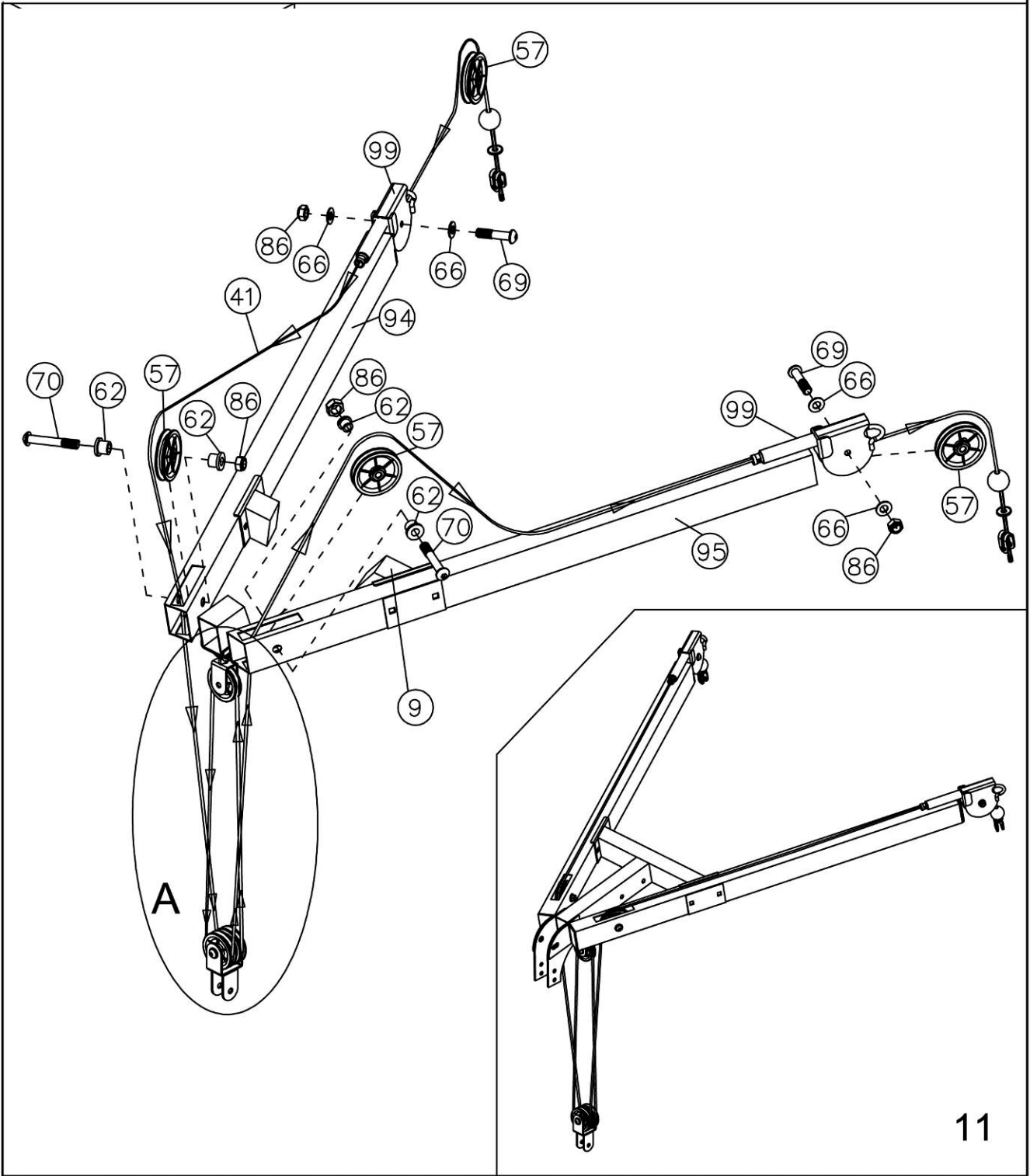

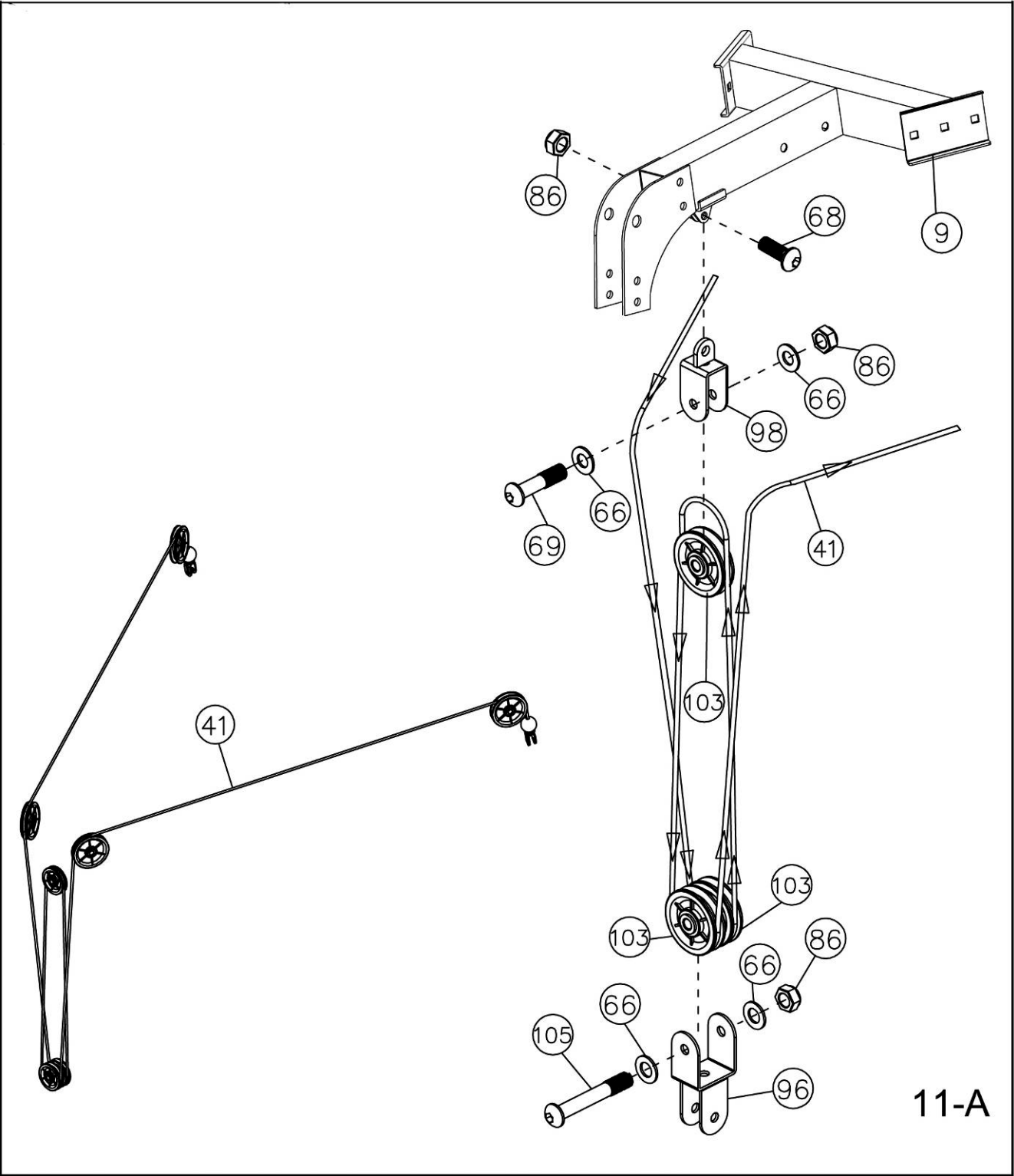

Sliding Weight Post Cable assembly instruction Step-12

- A.) Attach one end of the 138" Sliding Weight Post Cable (#102) to the triangular bracket on the Sliding Weight post (#14). Secure it with one M10 x 1" Allen Bolt (#69), two Ø ¾" Washers (#66), and one M10 Aircraft Nut (#86).
- B.) Draw the Cable upward to the Pulley on top of the Rear Upper Frame (#9).
- C.) Draw the Cable around the Pulley then downward. Attach a Small Pulley (#103) to a Double Floating Pulley Bracket (#18). Secure it with one M10 x 1 ¾" Allen Bolt (#69), two Ø ¾" Washers (#66), and one M10 Aircraft Nut (#86).
- D.) Draw the Cable around the Pulley then upward to the Triple Floating Pulley Bracket (#96).
- E.) Attach a Small Pulley (#103) to open Bracket. Secure it with one M10 x 1 ¾" Allen Bolt (#69), two Ø ¾" Washers (#66), and one M10 Aircraft Nut (#86). Draw the Cable around the Pulley then downward to the open bracket on the Pulley Support Frame (#97).
- F.) Attach a Small Pulley to the open bracket. Secure it with one M10 x 1 ¾" Allen Bolt (#69), two Ø ¾" Washers (#66), and one M10 Aircraft Nut (#86). Draw the Cable around the Pulley and upward.
- G.) Connect the Cable to a Short Chain (#63) with a C-clip (#61). Connect the Short Chain to the Single Floating Pulley Bracket (#19). Secure the Chain to the bracket with one M10 x 1" Allen Bolt (#68) and one M10 Aircraft Nut (#86).
- H.) After completing the entire cable installations, come back to this Short Chain to adjust the tension of the Cable System by adjusting the length of the Chain with the C-clip.

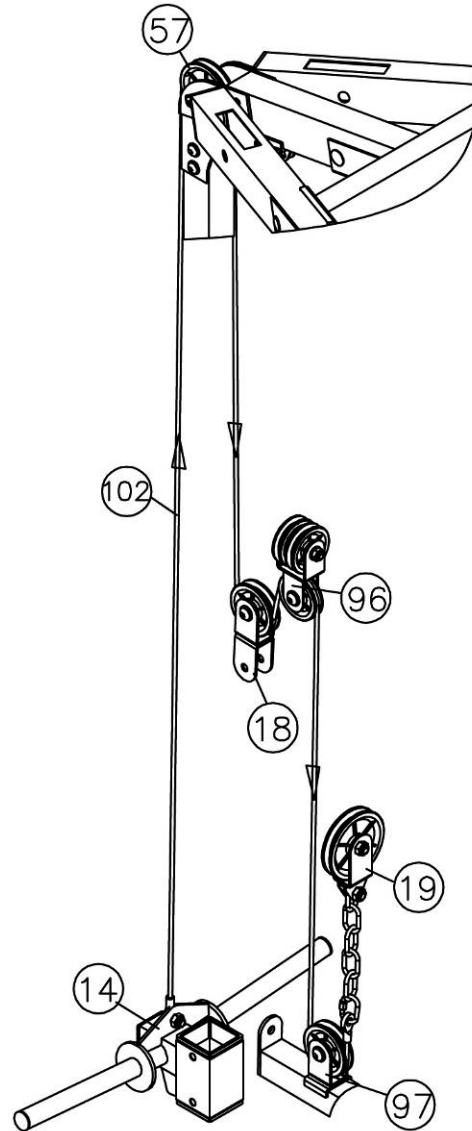
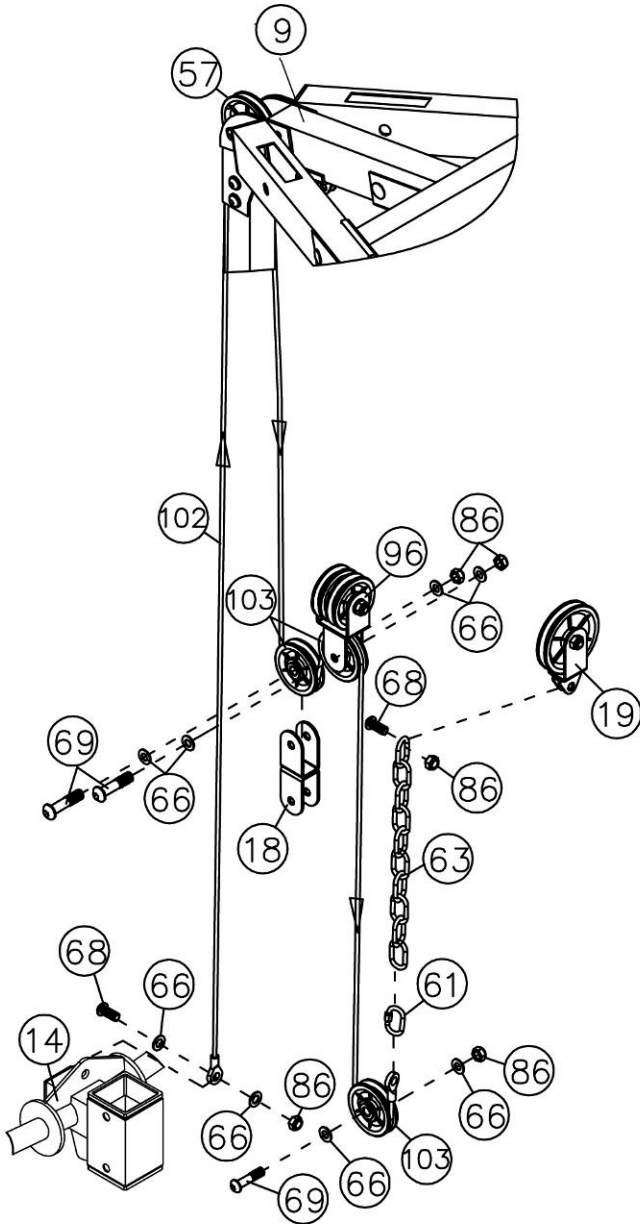
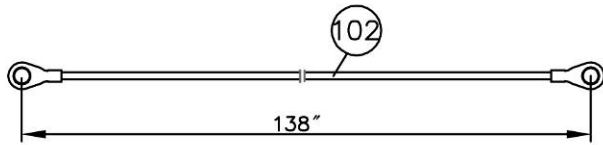

12

Lower Cable assembly instruction Step-13

- A.) Attach the 59" Lower Cable (#40) to a Pulley (#57) to the bottom opening on the Rear Vertical Beam (#6). Secure the Pulley to the Rear Vertical Beam with the Foot Plate (#16), one M10 x 3 3/8" Allen Bolt (#73), two Ø 3/4" Washers (#66), and one M10 Aircraft Nut (#86). Secure the Foot Plate to the Cross Brace (#2) with two M10 x 1" Allen Bolts (#68), four Ø 3/4" Washers (#66), and two M10 Aircraft Nuts (#86).
- B.) Draw the Cable underneath the Pulley to the open bracket on the Weight Glide Base (#8). Attach a Pulley to the bracket. Secure it with one M10 x 1 3/4" Allen Bolt (#69), two Ø 3/4" Washers (#66), and one M10 Aircraft Nut (#86).
- C.) Draw the Cable around the Pulley then upward to the Double Floating Pulley Bracket (#18). Attach a Small Pulley (#103) to the Bracket. Secure it with one M10 x 1 3/4" Allen Bolt (#69), two Ø 3/4" Washers (#66), and one M10 Aircraft Nut (#86).
- D.) Draw the Cable around the Pulley then downward to the open bracket on the Pulley Support Frame (#97). Secure the end of the Cable with one M10 x 1" Allen Bolt (#68), two Ø 3/4" Washers (#66), and one M10 Aircraft Nut (#86).
- E.) Connect the Shiver Bar (#30) to a Long Chain (#64) with a C-clip (#61). Connect the Long Chain to the Cable with another C-clip.

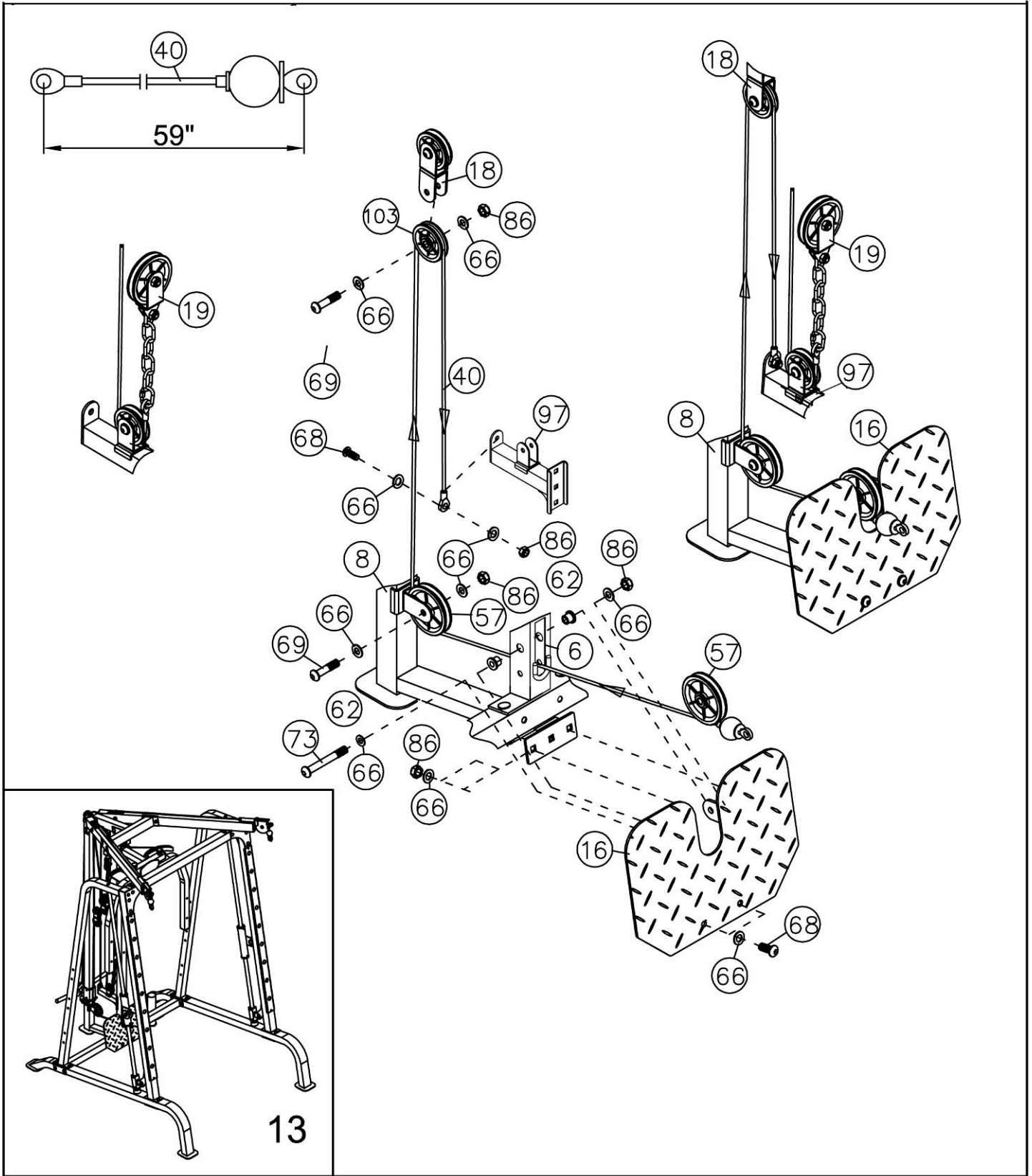

WEIGHT CAPACITY AND DIMENSION

1. Maximum user weight: 300 lbs.
2. Maximum weight on Sliding Weight Post (#14): 300 lbs (150lbs on each side)
3. Maximum weight on storage Weight Post (#17): 100 lbs
4. Maximum weight on Bar Holder (#21 & #22) and Safety Holder (#23 & #24): 300 lbs
5. Maximum weight on Weight Bar (#28): 300 lbs
6. Maximum weight on Bench: 600lbs (including user weights)
7. Cage assembled dimensions: 70" x 83" x 86"
8. Bench assembled dimensions: 75" x 28.5" x 47"

CARE AND MAINTENANCE

1. Lubricate moving parts with WD-40 or light oil periodically.
2. Inspect and tighten all parts before using the equipment.
3. The equipment can be cleaned using a damp cloth and mild non-abrasive detergent.
DO NOT use solvents.
4. Examine the equipment regularly for signs of damage or wear.
5. Replace any defective components immediately and/or keep the equipment out of use until repair.
6. **Failure to examine regularly may affect the safety level of the equipment.**

OPERATION NOTES

This equipment should be placed on flat surface. The incline or decline of surface should be limited to 3% or less for best performance and safety.

Cable Tension Adjustment

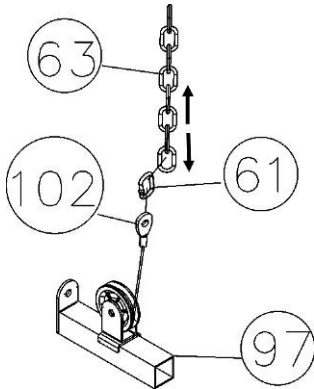

Adjust the tension of the Cable System by adjusting the length of Short Chain (#63) which is connected by C-clip (#61) to Sliding Weight Post Cable (#102).

If the tension is too loose, move C-clip (#61) up to shorten the length of Chain.

If the tension is too tight, move C-clip (#61) down to extend the length of Chain.

Bench Backrest Adjustment Angles

Backrest adjustment angle ranges from -13° to 81° .

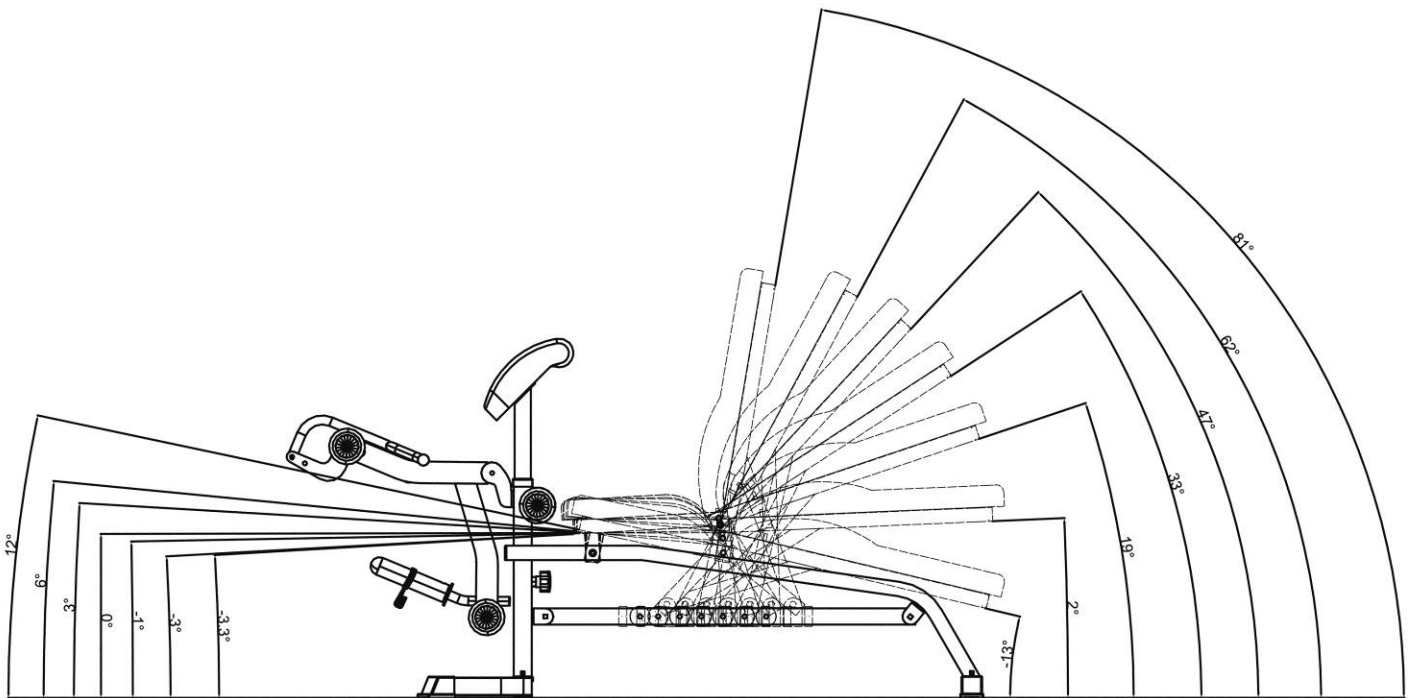

MD-5139 WEIGHT RESISTANCE CHART

Station	Ratio	Example
Low Pulley	200%	10 lb. plate creates 20 lb. resistance
Lat Pull	50%	10 lb. plate creates 5 lb. resistance
Butterfly (both arms)	100%	10 lb. plate creates 10 lb. resistance
Left Cross-Over	50%	10 lb. plate creates 5 lb resistance
Right Cross-Over	50%	10 lb. plate creates 5 lb resistance

***Numbers are approximate. Actual resistance may vary.**

MD-5139 SMITH MACHINE PARTS LIST

PART NO	DESCRIPTION	SIZE	QUANTITY
1	Base Frame		2
2	Cross Brace		1
3	Front Vertical Beam		2
4	Left Vertical Frame		1
5	Right Vertical Frame		1
6	Rear Vertical Frame		1
7	Weight Guide Post		1
8	Weight Guide Base		1
9	Rear Upper Frame		1
10	Left Butterfly		1
11	Right Butterfly		1
12	Butterfly Base		1
13	Butterfly Pulley Bracket		1
14	Sliding Weight Post		1
15	Front Top Beam		1
16	Foot Plate		1
17	Weight Post		6
18	Double Floating Pulley Bracket		1
19	Single Floating Pulley Bracket		1
20	Swivel Pulley Bracket		2
21	Left Bar Holder		1
22	Right Bar Holder		1
23	Left Safety Catch		1
24	Right Safety Catch		1
25	Guide Rod		2
26	Safety Stop Frame		2
27	Lifting Sleeve		1
28	Weight Bar		1
29	Lat Bar		1
30	Shiver Bar		1
31	Curl Handle		1
32	Chrome Panel		2
33	Triangle Bracket	7 1/8" x 7 1/8"	2
34	Bracket	5 1/8" x 2 3/4"	2
35	Bracket	5 1/8" x 2 3/8"	2
36	Bracket	4 3/4" x 2"	9
37	Bracket	6 1/4" x 2"	2
38	Backrest Board		1
39	Butterfly Arm Pad		2
40	Lower Cable	59"	1
41	Upper Cable	229"	1

42	Butterfly Cable	87"	1
43	Olympic Sleeve		8
44	Long Olympic Sleeve		2
45	Curl Bar Handle Grip		2
46	Lat Bar Grip		2
47	Bushing	Ø 1" x 3 1/8"	2
48	Bushing	Ø 1 1/2" x 1"	2
49	End Cap	1 1/2" x 1 1/2"	2
50	End Cap	1 3/4" x 1 3/4"	7
51	End Cap	2 3/8" x 2 3/8"	2
52	End Cap	2 3/4" x 2"	2
53	Cone-shaped End Cap	Ø 1"	12
54	Sleeve	2 3/8" x 2"	2
55	Sliding Sleeve		4
56	Lock Ring		2
57	Pulley		10
58	Rubber Bumper	Ø 1 3/4"	1
59	Rubber Bumper	Ø 2 1/2"	2
60	Spring Clip	Ø 1 7/8"	10
61	C-clip		5
62	Pulley Bushing	Ø 7/8" x 5/8"	6
63	Short Chain	10-link	2
64	Long Chain	15-link	1
65	Washer	Ø 5/8"	6
66	Washer	Ø 3/4"	100
67	Washer	Ø 1 1/2"	2
68	Allen Bolt	M10 x 1"	12
69	Allen Bolt	M10 x 1 3/4"	11
70	Allen Bolt	M10 x 2 1/2"	2
71	Allen Bolt	M10 x 3"	2
72	Allen Bolt	M10 x 3 1/8"	2
73	Allen Bolt	M10 x 3 3/8"	2
74	Carriage Bolt	M10 x 1"	4
75	Carriage Bolt	M10 x 2 3/4"	22
76	Carriage Bolt	M10 x 3"	10
77	Carriage Bolt	M10 x 3 1/8"	4
78	Carriage Bolt	M10 x 3 3/8"	8
79	Carriage Bolt	M10 x 3 1/2"	4
80	Allen Bolt	M8 x 2 1/2"	6
81	Allen Bolt	M8 x 3/8"	2
82	Phillips Screw	M6 x 5/8"	1
83	Allen Bolt	M6 x 1 1/4"	2
84	Chrome Panel Screw		8

85	Aircraft Nut	M6	2
86	Aircraft Nut	M10	82
87	End Cap	Ø 1"	6
88	V Bar		1
89	Ankle Strap		1
90	Single Handle Strap		2
91	Triceps Rope		1
92	Lower Safety Stop Frame		2
93	Safety Hook		2
94	Left Upper Frame		1
95	Right Upper Frame		1
96	Triple Floating Pulley Bracket		1
97	Pulley Support Frame		1
98	Single Small Pulley Bracket		1
99	Cross-Over Swivel Pulley Bracket		2
100	Bushing	Ø 7/8" x Ø 5/8"	2
101	Bracket	4 3/4" x 2 3/4"	2
102	Sliding Weight Post Cable	138"	1
103	Small Pulley		7
104	Allen Bolt	M10 x 1 1/8"	2
105	Allen Bolt	M10 x 2 3/4"	1
106	Allen Screw	M6 x 1/4"	4
107	Linear Bearing		4
108	Linear Bearing Cover		4
109	Phillips Screw	M6 x 1/4"	4
	Allen Wrench (Tool)	6#	1
	Allen Wrench (Tool)	5#	1
	Allen Wrench (Tool)	4#	1
	Allen Wrench (Tool)	3#	1

MD-5139 SMITH MACHINE EXPLODED DIAGRAM

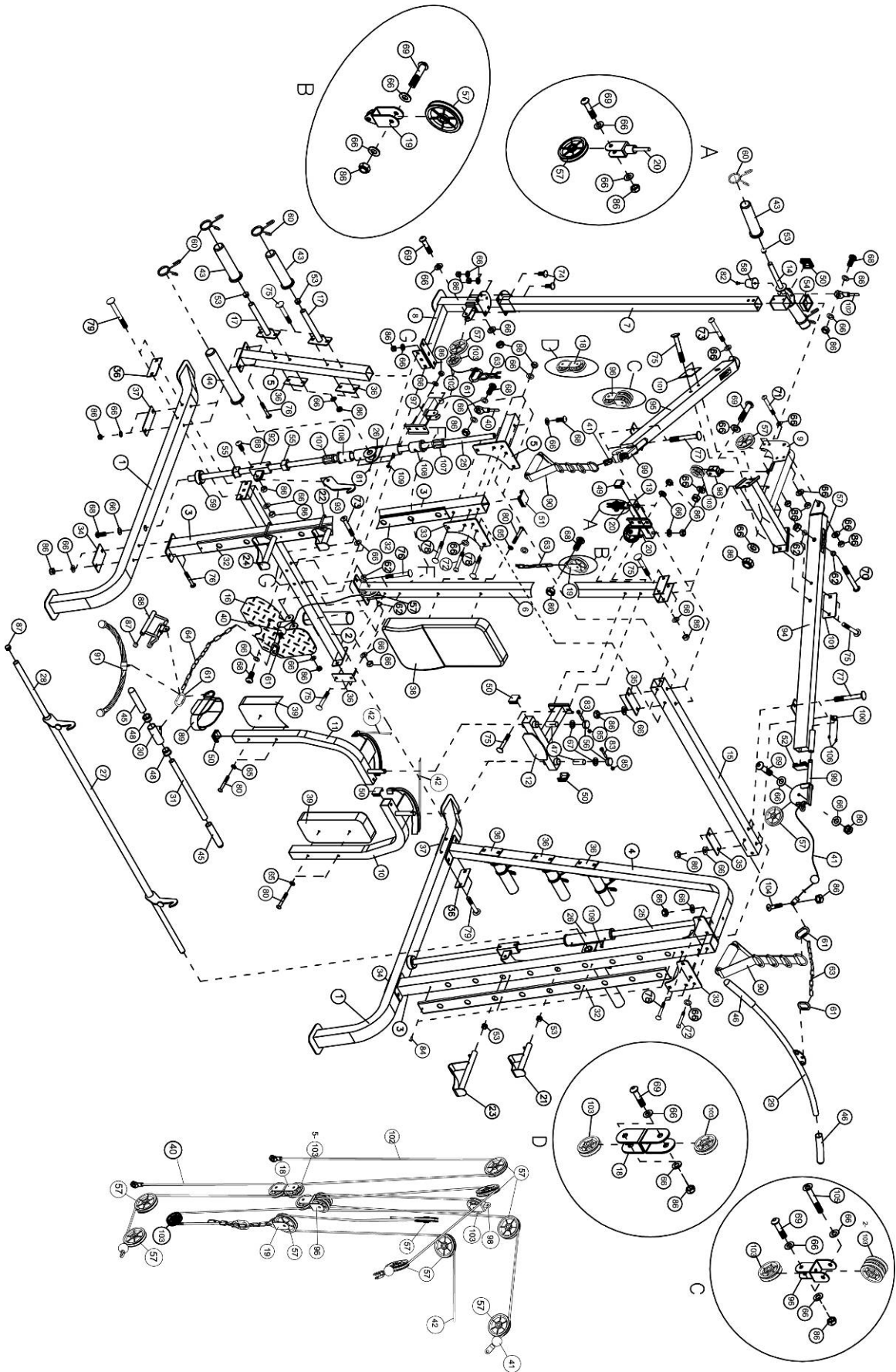

MD-5139 BENCH PARTS LIST

PART NO	DESCRIPTION	SIZE	QUANTITY
1	Main Frame		1
2	Front Stabilizer		1
3	Rear Stabilizer		1
4	Arm Curl Stand		1
5	Leg Developer		1
6	Seat Support Frame		2
7	Backrest Support		2
8	Sliding Block		1
9	Incline Adjustment Bar		1
10	Foam Tube		3
11	Arm Curl Handle		1
12	Manual		1
13	Seat Pad		1
14	Backrest Board		1
15	Arm Curl Pad		1
16	Curl Bar Handle Grip		2
17	Axle		1
18	Bushing	Ø 2 3/8"	2
19	Tool (Allen Wrenches)		4
20	Olympic Sleeve		1
21	Lock Pin	3"	1
22	Spring Clip	Ø 1 7/8"	1
23	Lock Knob	M18	2
24	Foam Roll		6
25	Foam Roll End Cap		6
26	Bushing	Ø 1" x 3/4"	2
27	Bushing	Ø 3/4" x 1/4"	16
28	End Cap	3 1/8" x 1 5/8"	1
29	Cone-shaped End Cap	Ø 1"	1
30	End Cap	Ø 1"	1
31	End Cap	1 5/8" x 2 3/8"	2
32	End Cap	1 5/8" x 3/4"	12
33	Sliding Block Sleeve	2"	3
34	Stabilizer End Cap		4
35	Carriage Bolt	M10 x 2 1/2"	2
36	Allen Bolt	M10 x 3/4"	6
37	Allen Bolt	M10 x 1 3/4"	2
38	Allen Bolt	M10 x 6 3/4"	1
39	Allen Bolt	M10 x 8 1/4"	1
40	Allen Bolt	M8 x 2"	8
41	Allen Bolt	M8 x 5/8"	2
42	Washer	Ø 3/4"	14

43	Washer	$\text{Ø } \frac{5}{8}''$	10
44	Aircraft Nut	M10	4

MD-5139 BENCH EXPLODED DIAGRAM

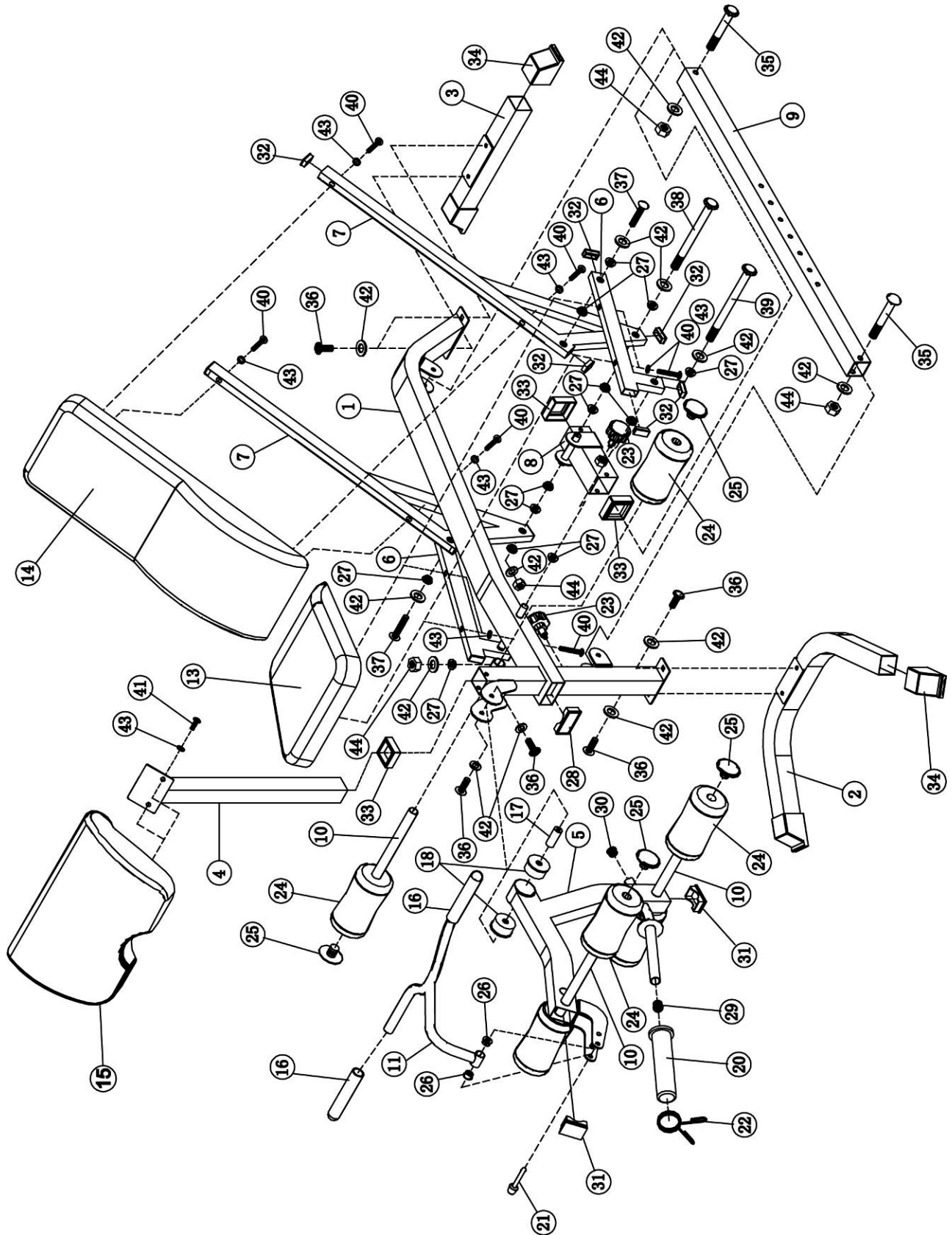

IMPEX[®] INC.

LIMITED WARRANTY

IMPEX Inc. ("IMPEX[®]") warrants this product to be free from defects in workmanship and material, under normal use and service conditions, for a period of two years on the Frame from the date of purchase. This warranty extends only to the original purchaser. IMPEX's obligation under this Warranty is limited to replacing or repairing, at IMPEX's option.

All returns must be pre-authorized by IMPEX. Pre-authorization may be obtained by calling IMPEX Customer Service Department at 1-800-999-8899. All freights on products returned to IMPEX must be prepaid by the customer. This warranty does not extend to any product or damage to a product caused by or attributable to freight damage, abuse, misuse, improper or abnormal usage or repairs not provided by an IMPEX authorized service centre or for products used for commercial or rental purposes. No other warranty beyond that specifically set forth above is authorized by IMPEX.

IMPEX is not responsible or liable for indirect, special or consequential damages arising out of or in connection with the use or performance of the product or other damages with respect to any economic loss, loss of property, loss of revenues or profits, loss of enjoyments or use, costs of removal, installation or other consequential damages of whatsoever natures. Some States do not allow the exclusion or limitation of incidental or consequential damages. Accordingly, the above limitation may not apply to you.

The warranty extended hereunder is in lieu of any and all other warranties and any implied warranties of merchantability or fitness for a particular purpose is limited in its scope and duration to the terms set forth herein. Some States do not allow limitations on how long an implied warranty lasts. Accordingly, the above limitation may not apply to you.

This warranty gives you specific legal right. You may also have other rights which vary from State to State. Register online at www.marcypro.com.

IMPEX[®] INC.
2801 S. Towne Ave.
Pomona, CA 91766

ORDERING REPLACEMENT PARTS

Replacement parts can be ordered by calling our Customer Service Department toll-free at **1-800-999-8899** during our regular business hours: Monday through Friday, 9 a.m. to 5 p.m. Pacific standard time.

support@impex-fitness.com

When ordering replacement parts, always give the following information.

1. Model
2. Description of Parts
3. Part Number
4. Date of Purchase